

1. **WARNING** - This kit contains lengths of cut aluminium. All care should be taken when assembling due to the likelihood of sharp edges.
2. The tambour mechanism contains a sprung counterbalance that is pre-set. Do not attempt to alter the mechanism tension without first contacting WAIVIS technical personnel.
3. No fittings are supplied with this unit as the final application is beyond the control of the manufacturer. As a recommendation, with cabinets made from 18mm Melamine Faced Chipboard (MFC), the Cassette Mounting Brackets and Pelmet Clip Profile should be fixed using 3.5 x 16mm (No.6 x 5/8") Countersunk Self-Tapping Chipboard screws. The Track Profile should be fixed using 3 x 12mm (No.4 x 1/2") Pan Head Self-Tapping Screws.

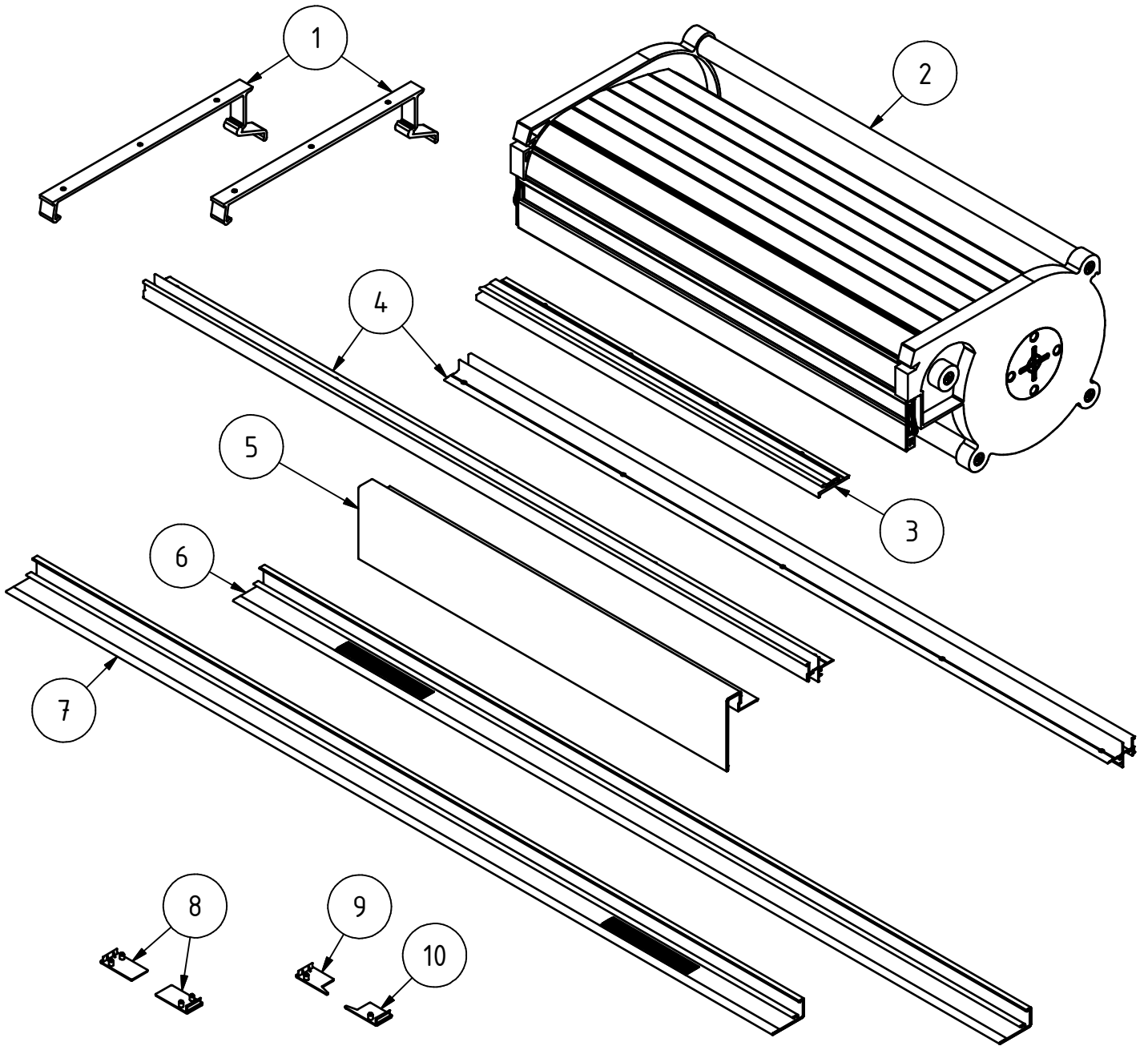

REFERENCE	DESCRIPTION	QUANTITY
1	Cassette Mounting Brackets	2
2	Tambour Cassette Mechanism	1
3	Pelmet Clip Profile	1
4	Track Profile	2
5	Pelmet Profile	1
6	Track Cover Profile - Left Hand Track	1
7	Track Cover Profile - Right Hand Track	1
8	End Cap Mouldings - Top	2
9	End Cap Moulding - Bottom Left	1
10	End Cap Moulding - Bottom Right	1
11	Drilling Template (Not Shown) for Mounting Brackets	1
12	Fixing Screws (Not Shown)	Not Supplied

1. For ease of assembly, invert cabinet.
2. Cut out and fold supplied drilling template as instructed.
3. Place templates as shown.
4. Ensuring you do not pierce the opposite side of the panel, drill blind pilot holes (Ø2mm) in cabinet top.
5. Remove Templates.

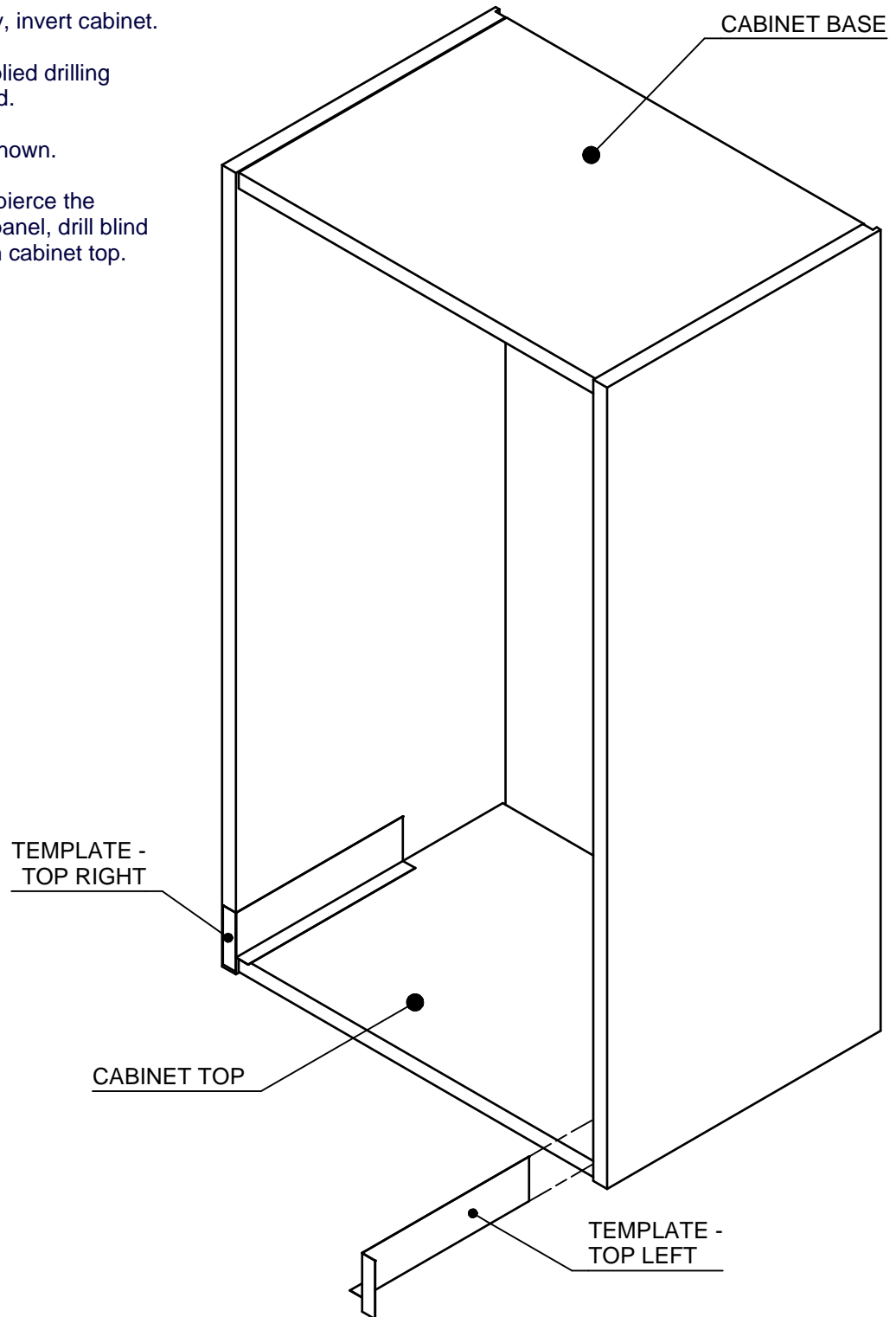

1. Align first cassette mounting bracket holes with pilot holes in cabinet top.
2. Fix cassette mounting bracket into position using 3 countersunk screws.
3. Repeat for second cassette mounting bracket.

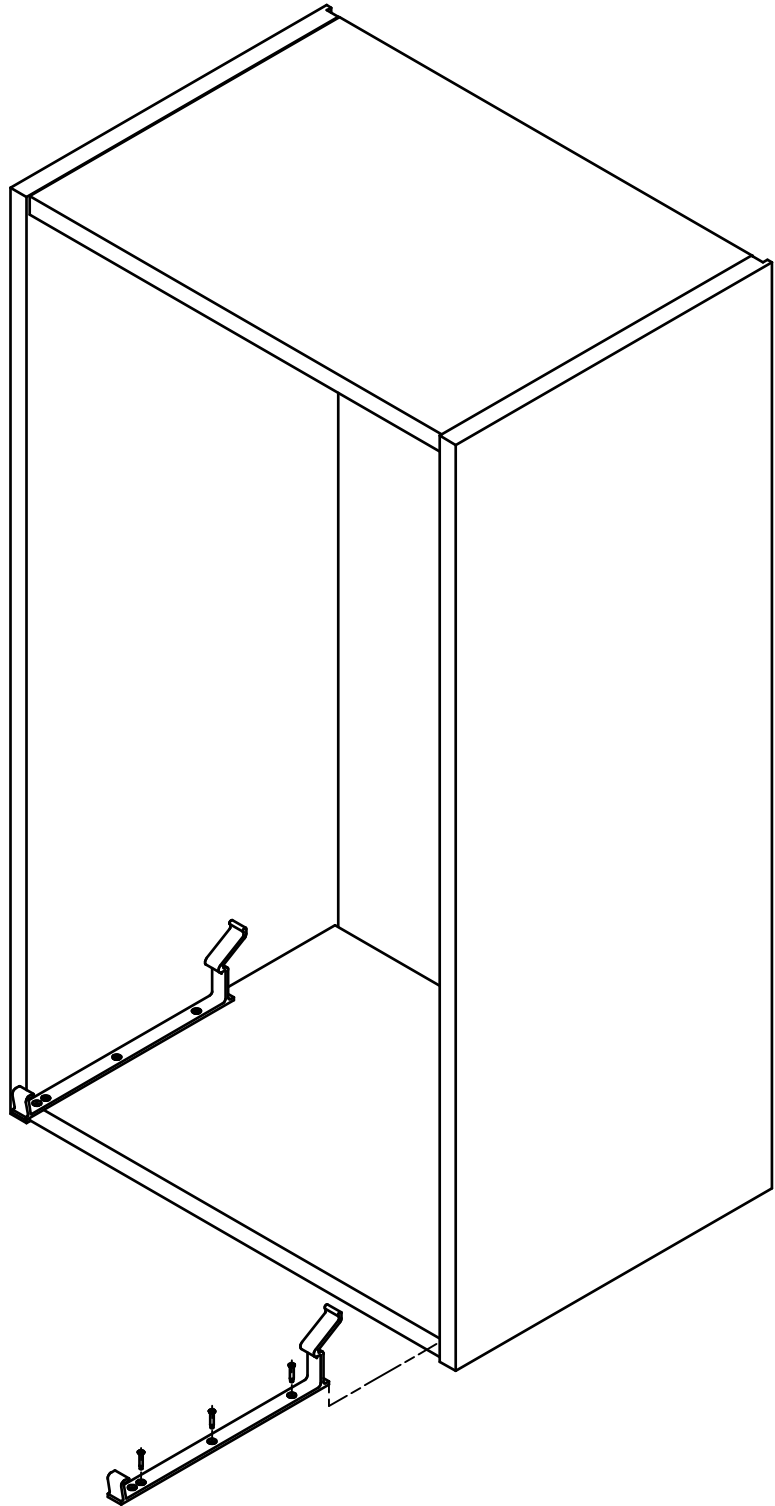

1. Remove liner paper from adhesive tape on rear of pelmet mounting clip
2. Affix pelmet mounting clip to cabinet top panel, as shown, such that there is an equidistant gap between the ends of the pelmet mounting clip and the cassette mounting brackets.
3. Fix pelmet mounting bracket to cabinet top panel using countersunk screws (as required).

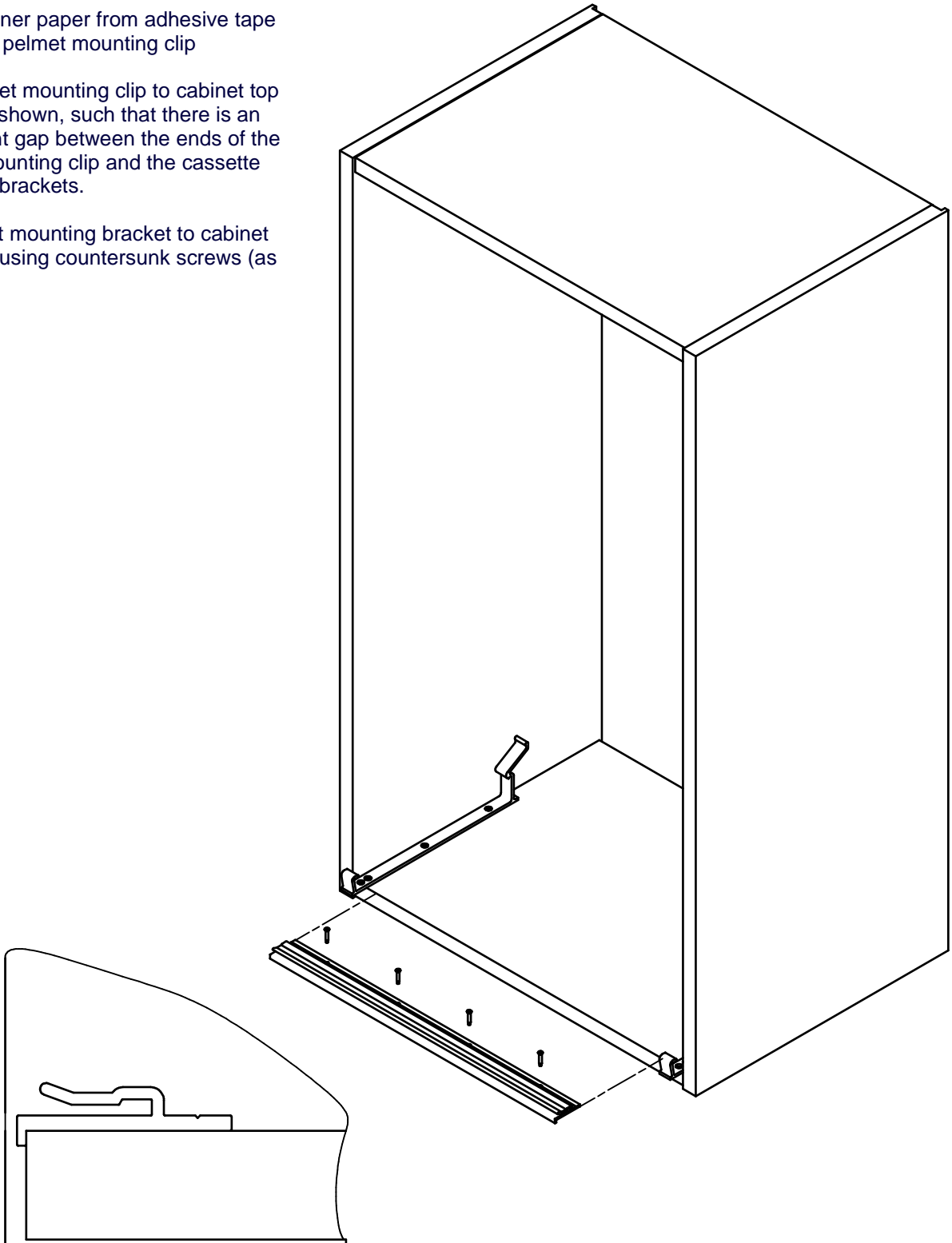

1. Position Cassette Mechanism into cabinet.
2. Locate undercut features on front of Cassette side mouldings on hooks at front of Cassette Mounting Brackets.
3. Rotate Cassette Mechanism as shown whilst opening the Cassette Mounting Bracket clip feature. (This may be done one side at a time.)
4. Ensure Cassette Mechanism is seated correctly and clip features are fully engaged.

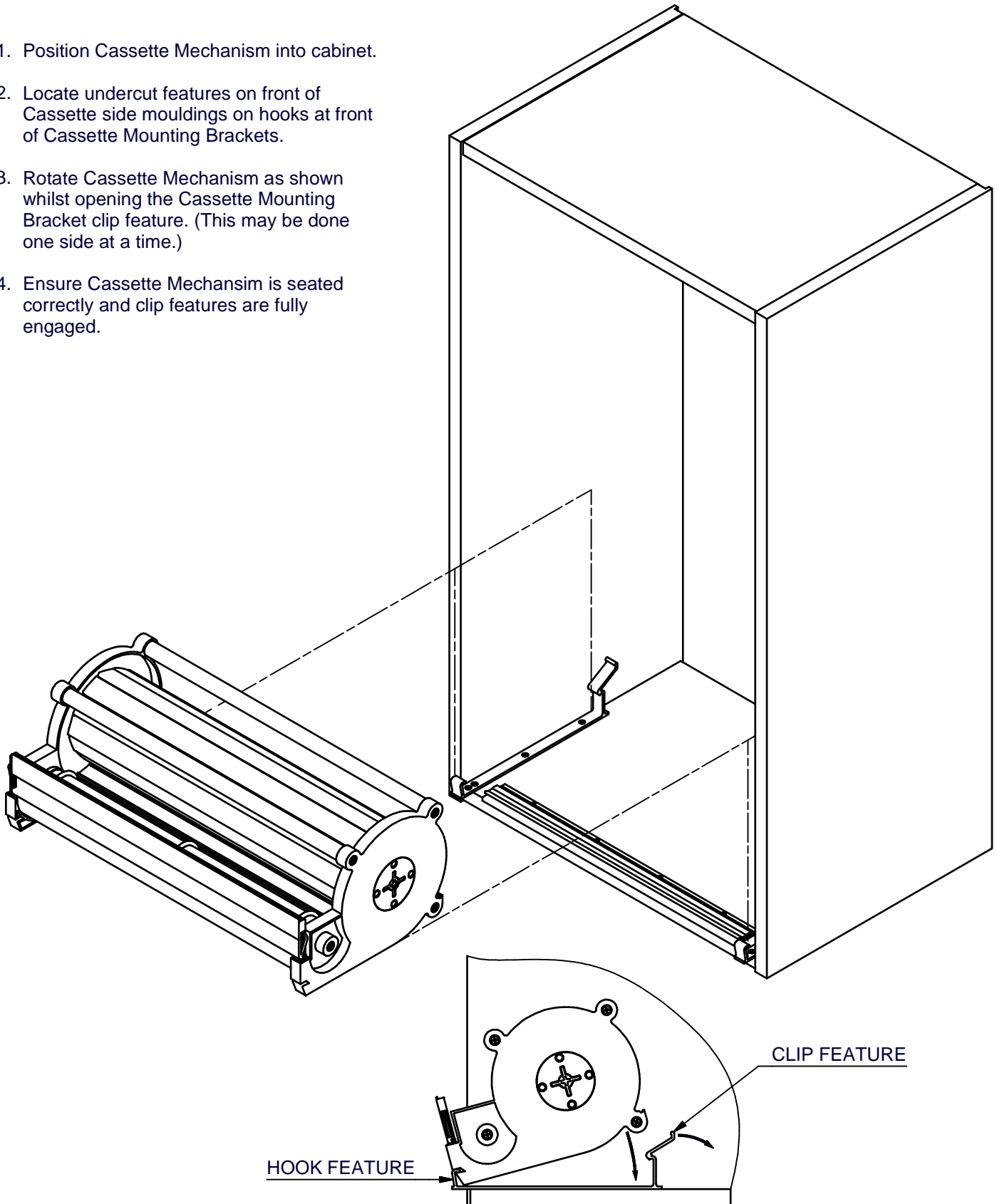

1. Orient first Track Profile relative to the cabinet.
2. Locate tambour handle profile into track recess.
3. Position Track Profile such that one end abuts the Cassette Mechanism side moulding and the inside angle of the Track Profile is tight against the panel edge and inside face.
4. Fix Track Profile into position using screws.
5. Repeat for second Track Profile.

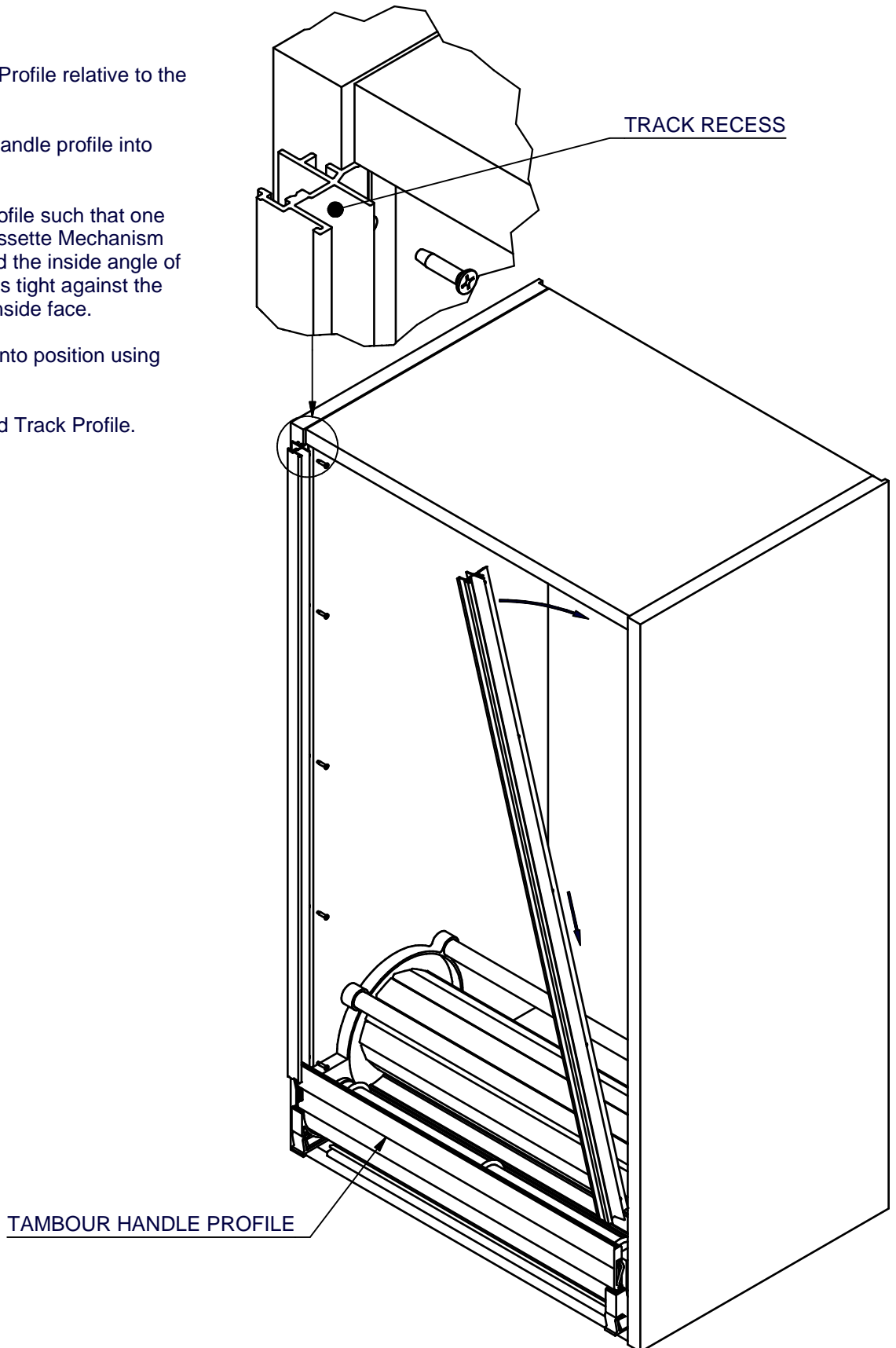

1. Rotate Cabinet into upright position.
2. Align tongue of Pelmet Profile with clip feature of Pelmet Mounting Bracket.
3. Press Pelmet Profile fully into Pelmet Mounting Bracket.

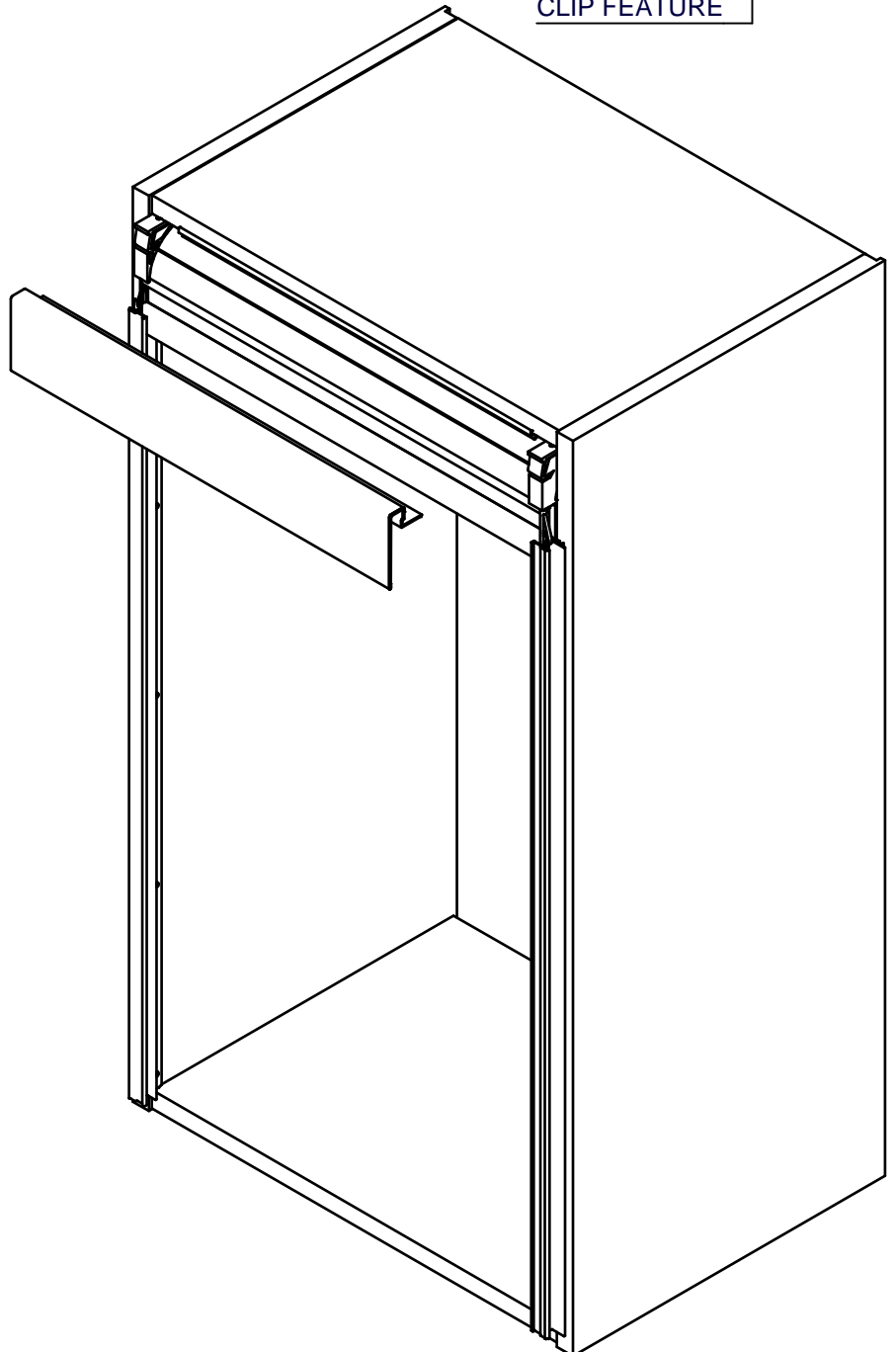
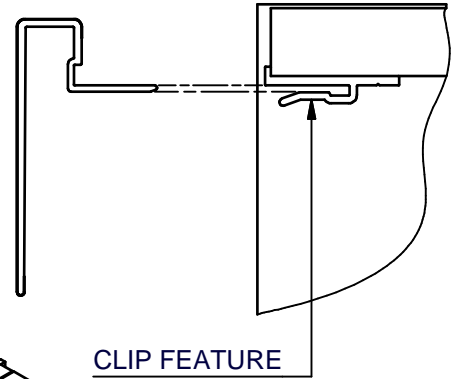

1. Align left hand Cover Profile with Track Profile and slide on until hook tape on the rear of the Cover Profile engages with the Track Profile.
2. Press down firmly on the top of the Cover Profile until top of the Cover Profile aligns with the top of the Cabinet.
3. Repeat for right hand Cover Profile.
4. Adjust Cover Profiles until distance from top and bottom of Cabinet to end of Cover Profiles is the same.
5. Adjust Pelmet Profile forward until front face of Pelmet Profile touches rear face of Cover Profile.

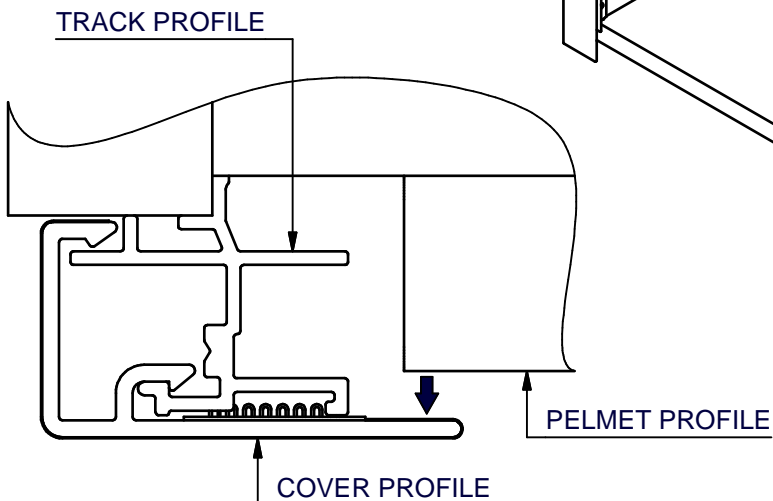
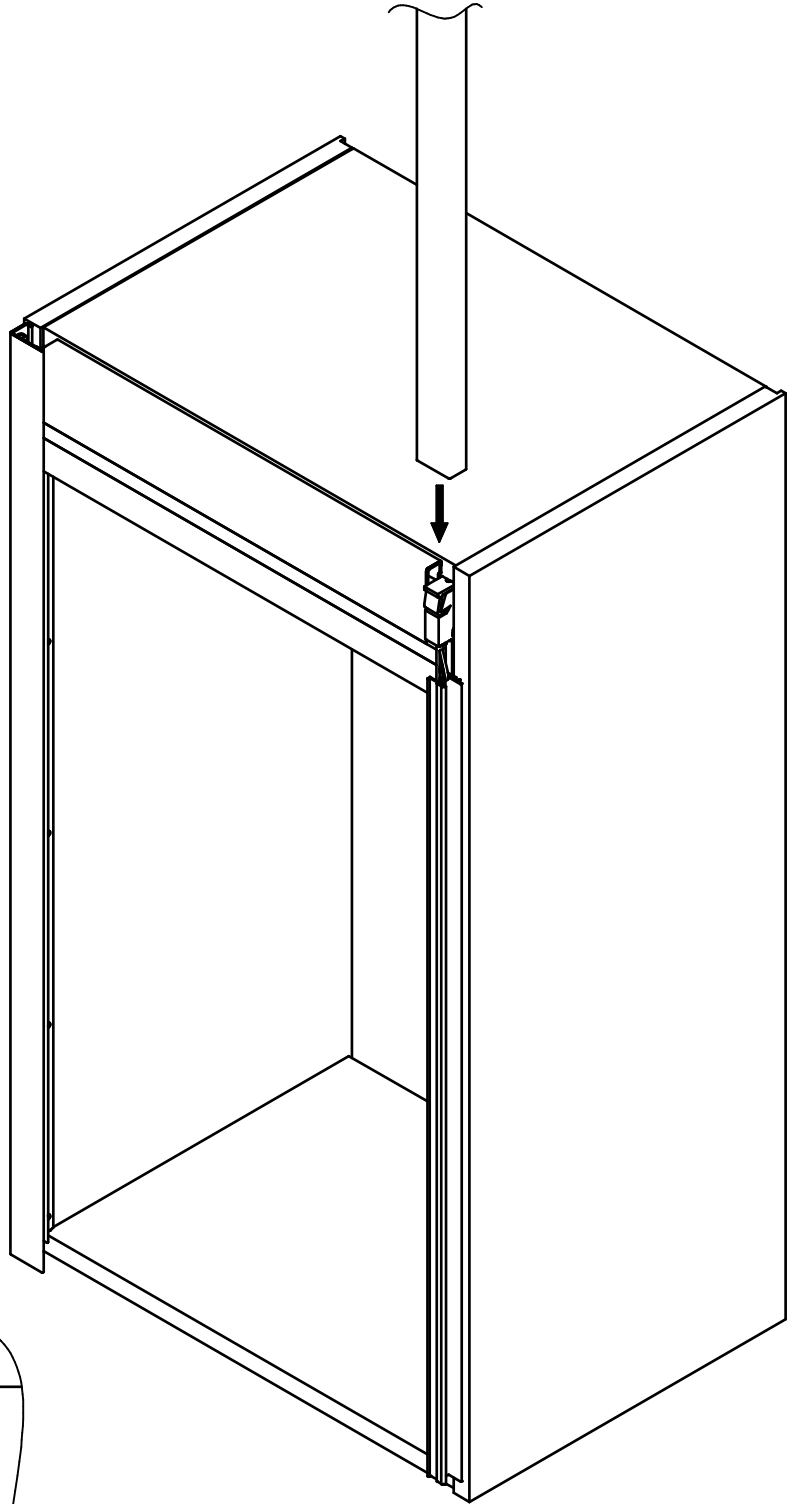

1. Insert Moulded End Caps into Cover Profiles.

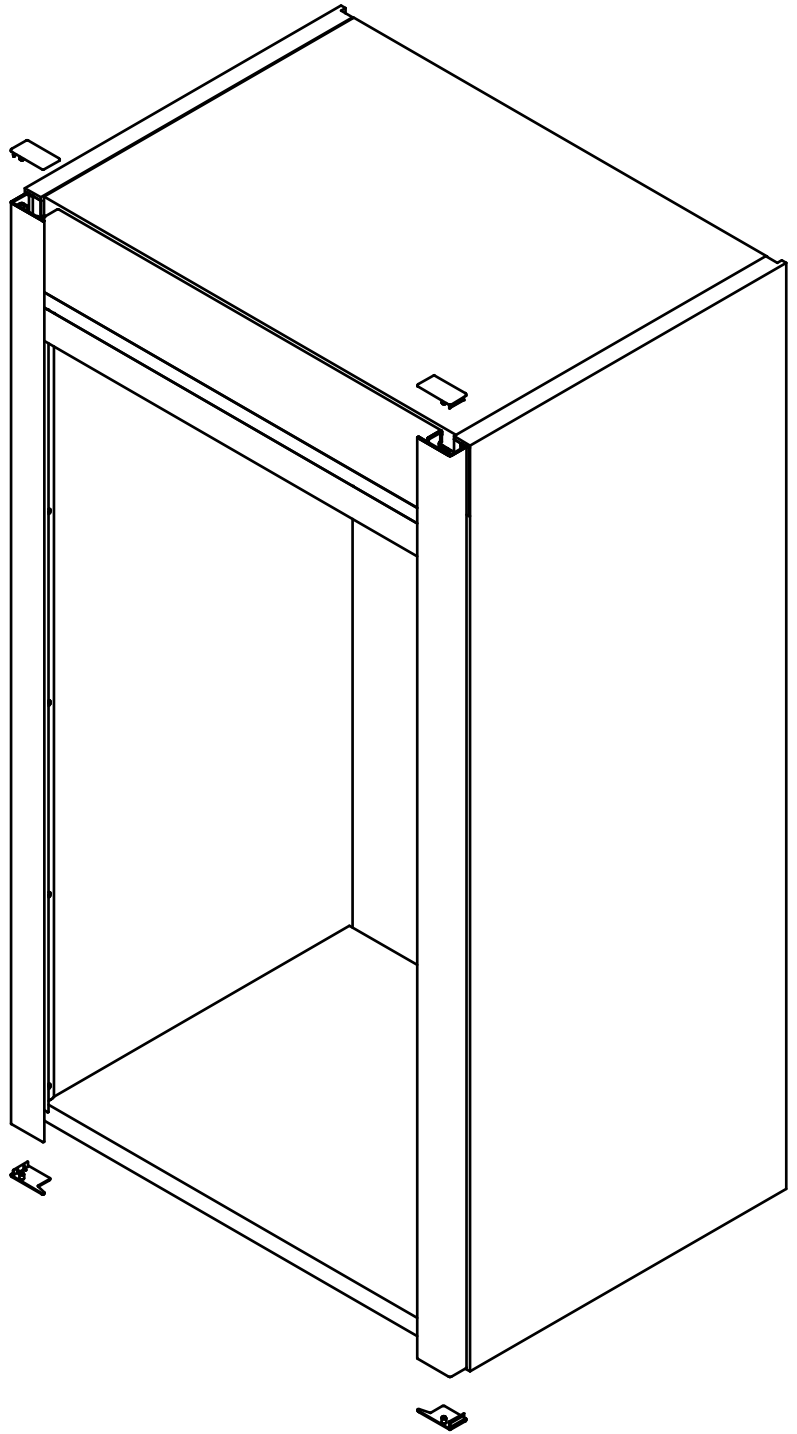

IF PRINTING FROM PDF
 FORMAT ENSURE PAPER
 SCALING IS SET TO 'NONE'.

Cut Along These Lines

Score Along These Lines — Fold Tabs As Indicated Through 90°

